

Voltage Range

The 2589-B will handle a wide range of AC and DC signals, and has incorporated the ability to select either 12V/24V, 48V, 110V, or 220V on a per channel basis using jumper selection. The selections are made individually for each of the 32 channels using jumpers. The operating ranges are as follows:

Range Setting	Operating Range
12/24V range	11 - 30 volts
48V range	40 - 56 volts
110V range	79 - 132 volts
220VAC range	164 - 265 volts

* NOTE: 220V range is AC only

NOTE:
Use caution when wiring with mixed voltages (i.e., 5VDC next to 110VAC).

NOTE:
For maximum protection against ESD damage, unused inputs should be tied to chassis ground.

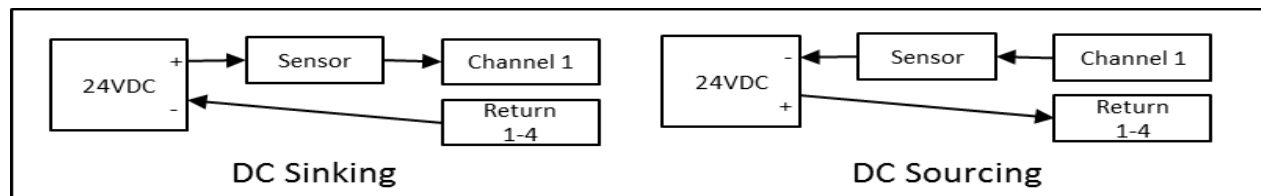

Figure 2. Typical External Wiring Application for the Model 2589-B

8/16/32 Point Configuration Explanation

The 2589-B was designed to be primarily a 32pt module. However, in order to provide maximum flexibility for the user, it may be configured as an 8 or 16 point module. Some details below to help the user better understand the jumper settings and labeling discrepancies for settings other than 32 points.

16 Point Mode: Move jumper in "Login" box to location JP130 to choose 16pt mode. Ensure the Isolation jumpers J3-6 are in Enhanced positions to correspond to the Siemens® 16 point modules (4 inputs/common); otherwise two 18 or 20 ga. jumper wires from AR to BR and CR to DR on the front panel connector are needed (see Figures, pg 2) to allow for 8 inputs/common. Also, note that many of the printed channels (CH 1-CH 32) on the PC board are no longer valid, nor are the front panel connector labels, or the LED channel indicators. (You may find it helpful to manually relabel the connector in the space provided for the 16 Point Login option.) If 16 Point is enabled, the following table's 16pt. row is the new correlation of PC board and connector label printing. For example, in 16 Point Login Configuration, the board marking for channel 10 (CH 10) would be the input channel 6. Likewise, the PC board marking for CH 28 would correlate to input channel 16. CTI offers an sticker you can apply to the front of the module which updates the LED labels. Contact CTI and ask for part number 506A-2588

8 Point Mode: Move jumper in "Login" box to location JP131 to choose 8pt mode. Ensure the Isolation jumpers J3-6 are in Enhanced positions to correspond to the Siemens® 8 point modules (2 inputs/common); otherwise two 18 or 20 ga. jumper wires from AR to BR and CR to DR on the front panel connector are needed (see Figures, pg 2) to allow for 4 inputs/common. Also, note that many of the printed channels (CH 1-CH 32) on the PC board are no longer valid, nor are the front panel connector labels, or the LED channel indicators. (You may find it helpful to manually relabel the connector in the space provided for the 8 Point Login option.) If 8 Point is enabled, the following table's 8pt. row is the new correlation of PC board and connector label printing. For example, in 8 Point Login Configuration, the board marking for channel 10 (CH 10) would be the input channel 4. Likewise, the PC board marking for CH 25 would correlate to input channel 7. CTI offers an sticker you can apply to the front of the module which updates the LED labels. Contact CTI and ask for part number 504A-2588 -8.

32 pt:	1	2	3	4	5	6	7	8	9	10	11	12	13	14	15	16	17	18	19	20	21	22	23	24	25	26	27	28	29	30	31	32
16 pt:	1	2	3	4	-	-	-	-	5	6	7	8	-	-	-	-	9	10	11	12	-	-	-	-	13	14	15	16	-	-	-	-
8 pt:	1	2	-	-	-	-	-	3	4	-	-	-	-	-	-	5	6	-	-	-	-	-	-	7	8	-	-	-	-	-	-	

PCB/Front Connector Label Channel Printing

2500 Series™ PLC System Preliminary Product Bulletin

2589-B 8/16/32-Point Universal Discrete Input Module



Specifications

Inputs per Module: 8, 16, or 32
Isolation: 1500 VDC channel-to-backplane
1500 VDC group-to-group

Input Voltage:

Range Setting	Operating Range
12/24V range	11 - 30 volts
48V range	40 - 56 volts
110V range	79 - 132 volts
220VAC range	164 - 265 volts

* NOTE: 220V range is AC only

Input Current: AC: 2.1 - 3.6 mA
DC: 2.5 - 4.3 mA

Operating Characteristics for Typical Input:

AC Voltage Input:

Turn ON Time: 4.0mS
Turn OFF Time: 15.0mS

DC Voltage Input:

Turn ON Time: 1.0mS
Turn OFF Time: 15.0mS

Connector: Removable

Wire Gauge: 14 - 22 AWG

Backplane Power: 3.6 Watts max.

Module Size: Single-wide

Operating Temperature: 0° to 60°C
(32° to 140°F)

Storage Temperature: -40° to 85°C
(-40° to 185°F)

Relative Humidity: 5% to 95%
(non-condensing)

Agency Approvals Pending:
UL, ULC, FM (Class 1, Div.2), CE

Shipping Weight: 1.5 lb. (0.68 Kg)

Description

The 2589-B 8/16/32-Point Universal Discrete Input Module accepts a wide range of voltage signals. It is designed to accept both AC and DC voltage allowing the user to pick and choose ranges on a single module. The 2589-B can be configured as an 8-point, 16-point, or 32-point module and can replace many Siemens® input products with no rewiring. Motor centers, optical sensors, limit switches and utility control are excellent examples of applications for this product.

Features

- CTI 2500 Series® or Simatic® 505 base format
- 8, 16, or 32 universal input points
- Replaces Siemens® 505-4008-A, 4016-A, 4032-A, 4208-A, 4216-A, 4232-A, 4308, 4316, 4316-A, 4332, 4408-A, 4416-A, 4432-A with no rewiring
- 1500V channel-to-PLC backplane and group-to-group isolation
- Wide 11V to 250V AC/DC range (selectable by group)
- Isolation in groups of 4 or 8 (selectable on 2589-B)
- Sourcing or sinking inputs
- Single-wide module



Control Technology Inc.

5734 Middlebrook Pike, Knoxville, TN 37921-5962
Phone: 865/584-0440 Fax: 865/584-5720 www.controltechnology.com

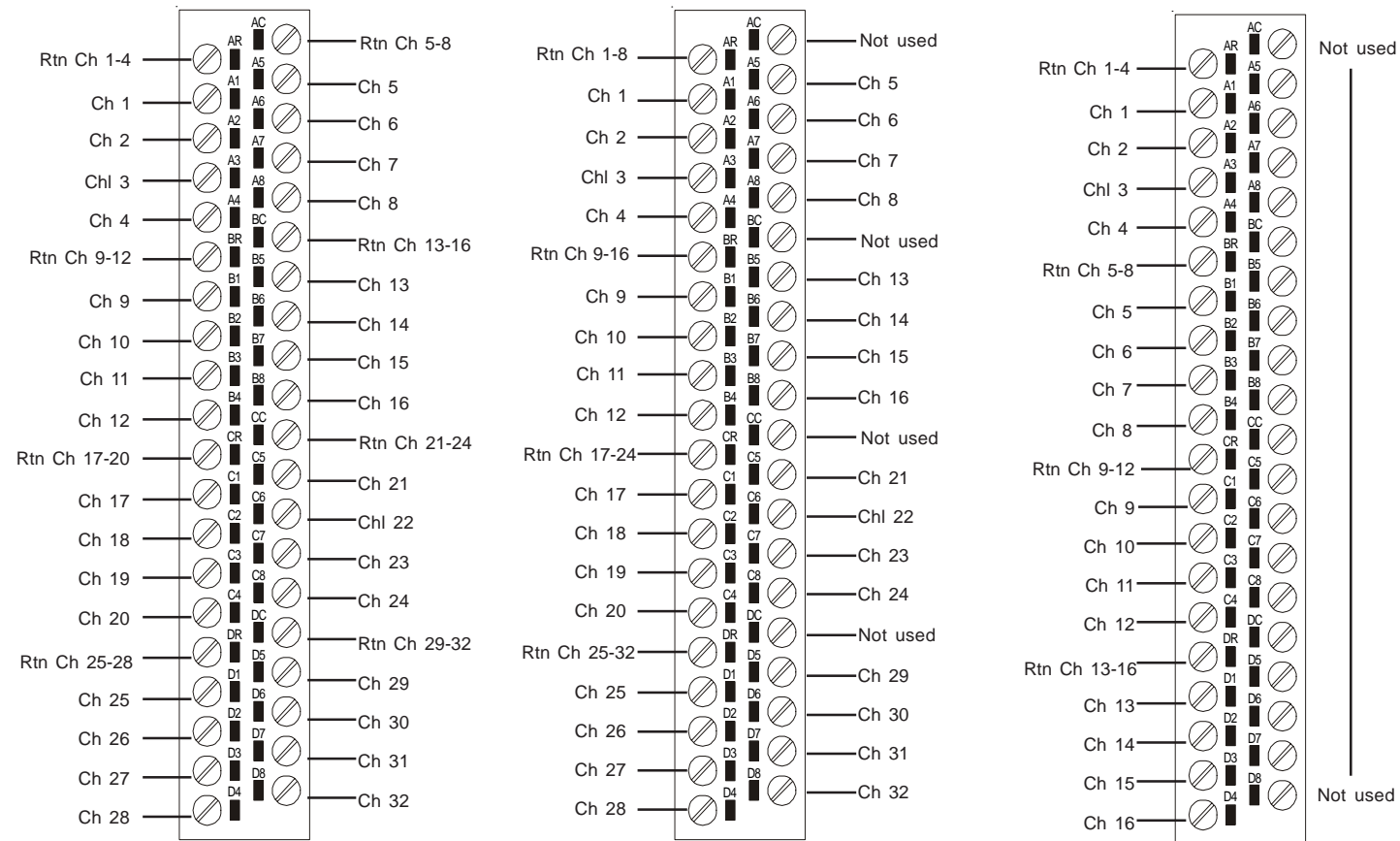

32-Point Enhanced Mode

32-Point Compatible Mode

16-Point Enhanced Mode

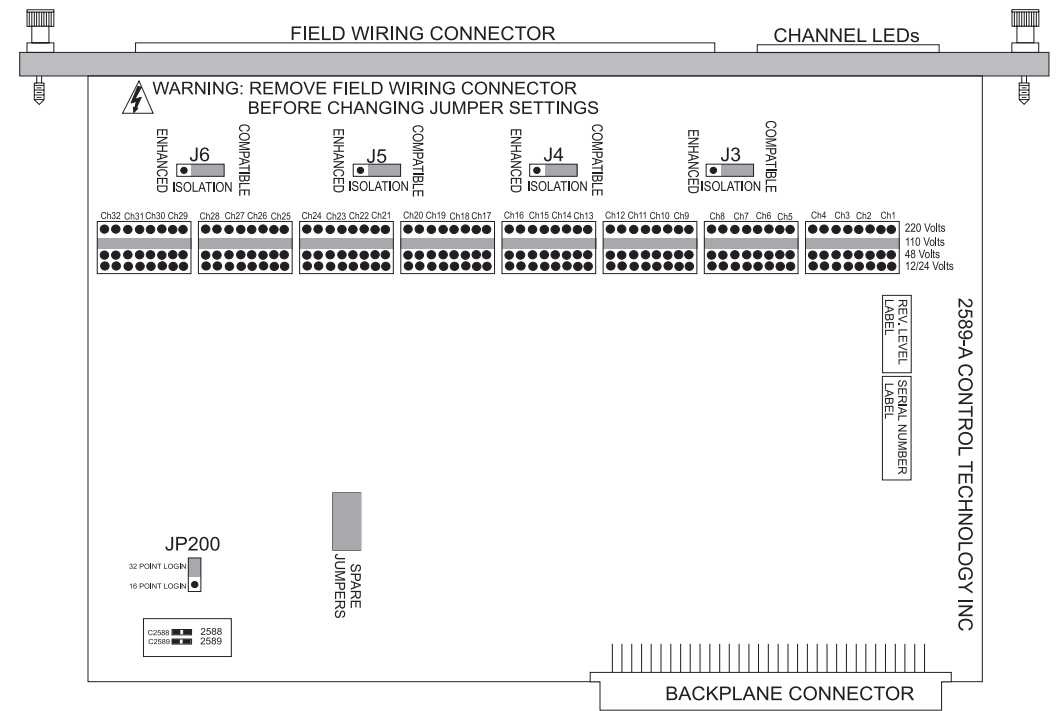
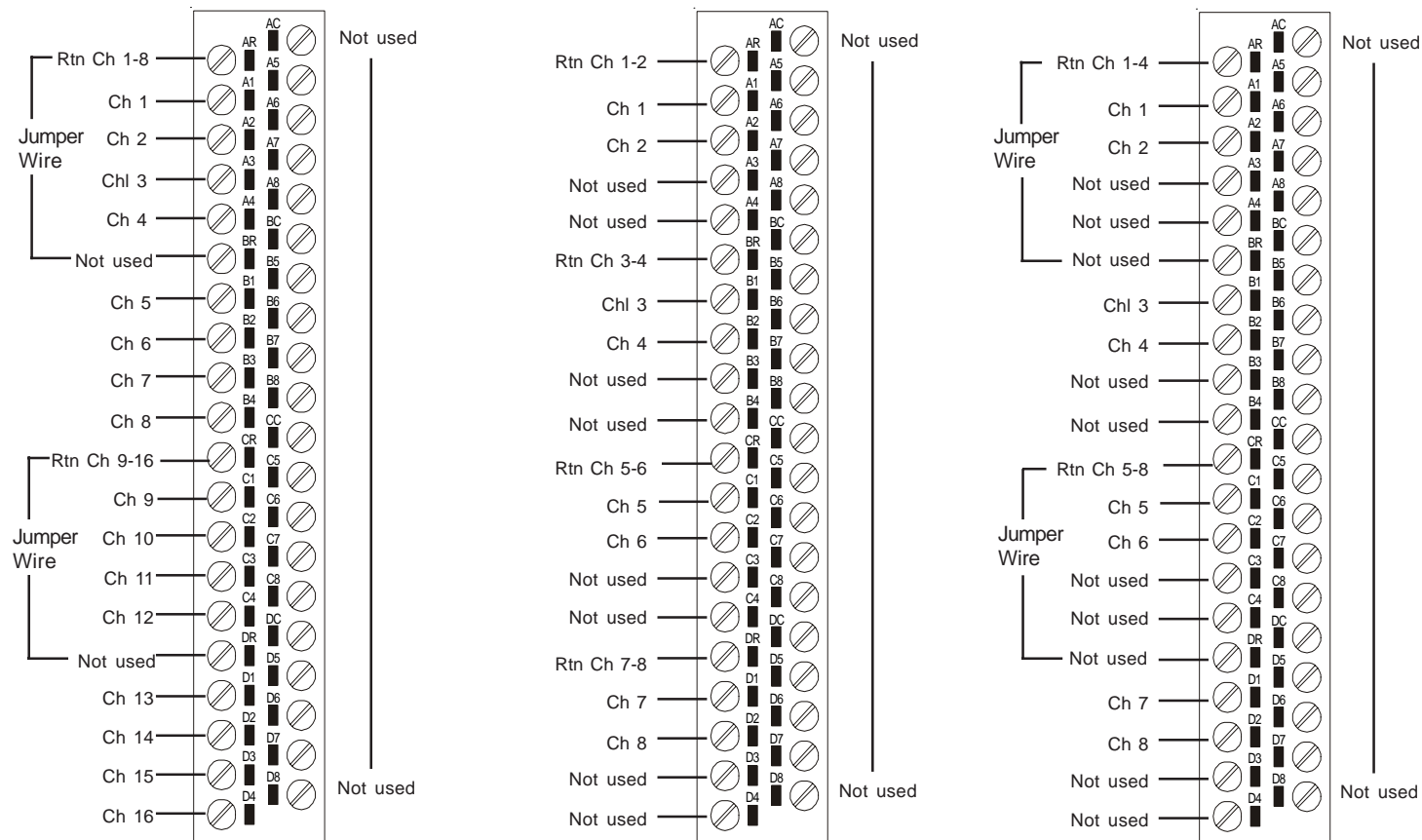

Figure 1. PCB Jumper Configuration Location

Standard Shipping Configuration

Jumper Configuration	
Jumper	Selection
J3, J4, J5, J6	Compatible
Ch. 1 through Ch. 32	110V range
JP129	32 Point Login

WARNING:
Remove field wiring connector before changing jumper settings.



16-Point Compatible Mode

8-Point Enhanced Mode

8-Point Compatible Mode

Isolation Configuration: 32pt Compatible Mode

The module is shipped in 32pt “Compatible” mode so that eight channels share a common return path. Jumpers J3-J6 are used to configure this isolation selection.

For example, if jumper J3 was placed in the “Compatible” position, then Channels 1-8 would share the same common return path and only one voltage type could be used on these eight channels. With this selection each group of eight channels is isolated from the other, allowing up to four different voltage types to be accommodated per module.

Isolation Configuration: 32pt Enhanced Mode

The user may also configure the module to “Enhanced” mode to allow four channels to share a common return, thereby allowing different input voltages to exist within a common grouping. Jumpers J3-J6 are also used to configure this selection.

For example, if the user places the J3 jumper in the “Enhanced” position, Channels 1-4 will share a common return path and Channels 5-8 will share another common return path. In this example each group of four channels is isolated from the other group of four channels. Because each group of four is isolated, the user may use one voltage type at different voltage levels in each group. So, in this example, Channels 1-4 could be 24VDC inputs and Channels 5-8 could be 110VAC inputs. Furthermore, the user may select a different configuration for J4, J5, or J6, allowing for further combinations of four or eight channels that share a common.