

2555-A 16-Channel Analog Input Module

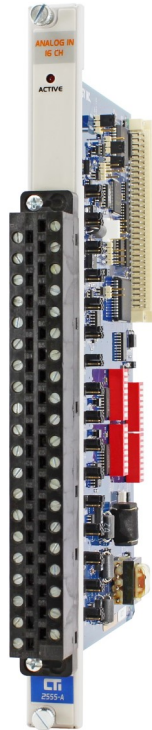

Description

The 2555-A is a high-speed 16-channel differential analog input module designed to be compatible with the CTI 2500 Series and Simatic® 505 I/O base. The 2555-A translates analog input signals into an equivalent digital word.

Features

- Simatic® 505 I/O base format
- 1500 VDC channel-to-PLC backplane isolation
- 14 Bits resolution Unipolar, 13 Bits + Sign Bipolar
- Fast 5.9 mSec update time
- No external power supply required for module
- No external current resistor required
- Microprocessor self-diagnostics
- Supports Immediate I/O

Specifications

Input Channels:

16 differential analog input channels
140 VRMS channel-to-channel CMR

Signal Range:

Unipolar: 0 to 5 VDC, 0 to 10 VDC, or 0 to 20 mA
Bipolar: -5 to +5VDC, -10 to +10VDC, or -20 to +20 mA

Update Time: 5.9 mSec no filtering
8.2 mSec digital filtering enabled

Filtering Time Constant: 80 mSec

DC Input Resistance:

Voltage Mode: 680K Ω

Current Mode: 250 Ω

Repeatability: 0.008%

Accuracy:

Voltage Mode: 0.057% of full scale @ 25°C

Current Mode: 0.2% of full scale @ 25°C

Resolution:

Unipolar:

14 bit plus sign

0-5 VDC range = 0.3125 mV/step

0-10 VDC range = 0.625 mV/step

0-20 mA range = 1.22 μ A/step

Bipolar:

13 bit plus sign

+5 to -5 VDC range = 0.625 mV/step

+10 to -10 VDC range = 1.25mV/step

Common Mode Rejection:

>86 db @ 60Hz (digital filtering disabled)

Normal Mode Rejection:

>45 db @ 60 Hz (digital filtering enabled)

Connector: 2500-40F

Wire Gauge: 14-22 AWG

Backplane Power: 5.0 Watts

Module Size: Single-wide

Input Overrange Protection: 500 V

Isolation: 1500 VDC channel-to-PLC

Shipping Weight: 1.5 lbs (0.68 Kg)

Additional Product Information:

On CTI's Website you find will links to the 2500 Series Std Environmental Specifications and the UL Agency Certificates of Compliance .



Control Technology Inc.

5734 Middlebrook Pike, Knoxville, TN 37921-5962

Phone: +1.865.584.0440 Fax: +1.865.584.5720

www.controltechnology.com

ROCK SOLID PERFORMANCE. TIMELESS COMPATIBILITY.

2555-A 16-Channel Analog Input Module

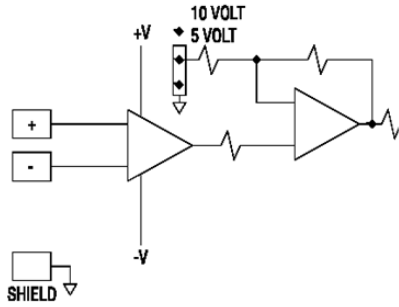

Typical Internal Circuit - Voltage Mode

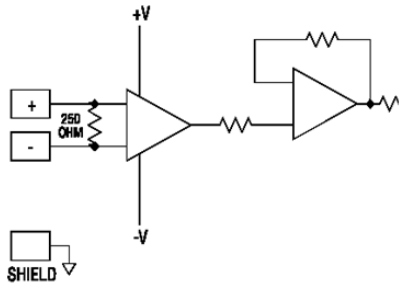

Typical Internal Circuit - Current Mode

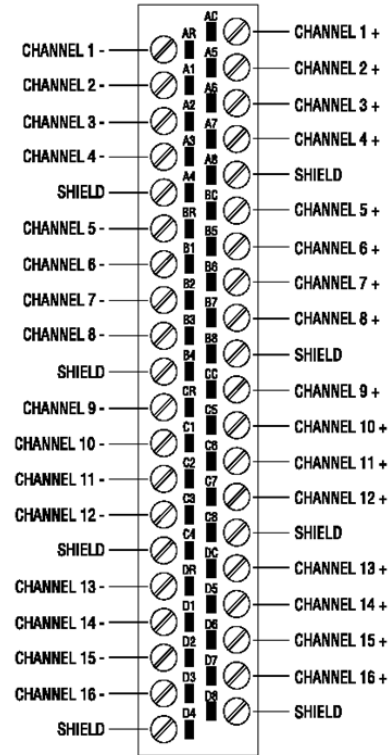

2555 Input Connector