



2500 Series Compact System



2500C-R4 System Chassis



2500C-R4 Chassis Specifications	
2500C-R4 Size	11.27"W x 3.88"D x 5.8" H 286.258mm W x9 8.58mm D x146.32mm H
2500C-R4 Wattage Rating	20 Watts
2500C-R4 Shipping Weight	3.0 lb (1.36kg)
2500C-Rx Common Specifications	
Operating Temp	0°C to 60°C (32°F to 140°F)
Storage Temp	-40°C to 85°C (-40°F to 185°F)
Relative Humidity	5% to 95% (non-condensing)
Agency Approvals Pending	UL, ULC, FM(Class 1, Div 2), CE

DESCRIPTION

The 2500C Compact System Chassis comes in 3 sizes : a 4, 8 and 16 slot Chassis. This allows the user to select a size that will accept for 4, 8 or 16 Compact IO modules. All chassis provide a Power Supply and Base Controller slot as well as the IO slots. The chassis is designed for rear panel or subpanel mounting. The chassis backplane provides an IO Backplane as well as an additional high speed data exchange backplane which supports all the Compact System's advanced modules and coprocessor modules. This high speed data transfer backplane is incorporated into the same backplane connector as the standard IO backplane.

FEATURES

- 4, 8 and 16 IO slot chassis
- Subpanel mounted
- Passive Backplane Design for reliability
- All chassis support the high speed data transfer bus
- Aluminum construction protects against corrosion and keeps chassis weight at a minimum



Chassis

Grounding

Note:
It is very important that the chassis be grounded to earth using the ground lug shown above. The ground lug can be found on the lower left corner of the mounting flanges.

- Ensure that the ground wire resistance is less than 0.1ohm.
- Use the shortest possible length of #8-gauge copper wire to make the ground connection.

Specifications



Control Technology Inc.

5734 Middlebrook Pike, Knoxville, TN 37921-5914
Phone: +1.865.584.0440 Fax: +1.865.584.5720
www.controltechnology.com



2500C-R4 System Chassis

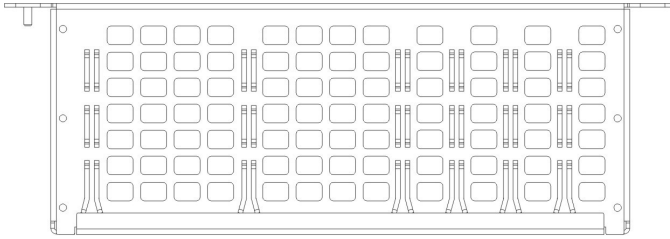

Top View

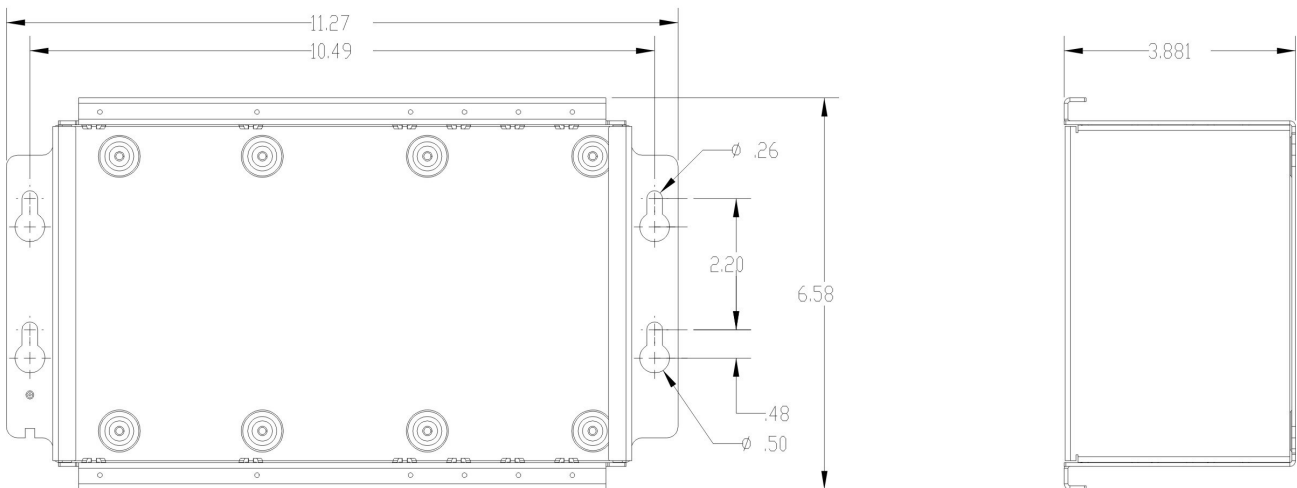

2500C-R4 Mounting Dimensions
Mounting Hole Dimensions

Mounting or Installing the 2500C Chassis

1. Mark the location of the base on the mounting panel surface including the mounting holes for the mounting ears.
2. There are 2 mounting ears. One found on each side of the chassis. Each of the ears provide two mounting hole locations which must be attached to the mounting panel using a bolt and nut or metal screws either self tapping or screwed into a drilled and tapped hole.
3. A minimum clearance of 3" should be allowed above and below the chassis to maximize convection airflow cooling.
4. Drill four holes in sub-panel of NEMA enclosure with a #21 drill bit. Tap the drilled holes with a #10-32 tap. Install #10 screws through each bracket hole to attach the base to the sub-panel.
5. The 2500C Chassis must be mounted in an appropriate enclosure based on the user environmental requirements.



Control Technology Inc.

5734 Middlebrook Pike, Knoxville, TN 37921-5914
Phone: +1.865.584.0440 Fax: +1.865.584.5720
www.controltechnology.com